

Specification of: REM BU-7180-63-24-50

Centrifugal smoke extract fan REM BU with PREMIUM EFFICIENCY motor in efficiency class IE3

Single inlet, with direct drive, without heat insulation. Suitable for smoke extraction in case of fire for temperatures up to +600°C, 120 minutes. Approved for installation outside the building and outside the fire chamber or inside the building and outside the fire chamber if sufficient cooling of the motor (outside air max. 40 °C) is provided and there is no danger of heat radiation or contact with persons and/or combustible objects! Fan tested according to DIN EN 12101-3 and CE-certified with the certification number 0036-CPR-RG01-18. Can be used for as a standard ventilation fan up to an air temperature of + 100 °C. Installation of the fan authorised for horizontal shaft position only. Casing made of steel sheet, welded and coated, equipped with mounting channels, suitable for handing RD/LG 0°, 90°, 180° and 270°. Connecting dimensions according to DIN 24154, range 4 (suction side) / DIN 24158, range 4 (discharge side). Centrifugal impeller with backward curved laminar blades, welded and coated, fitted to motor shaft of a flanged IEC motor, placed out of the main air stream, statically and dynamically balanced in accordance to DIN ISO 21940-11. Impeller and motor can be removed as a unit (without duct dismantling). Single-speed three-phase motor in B5 design, protection class IP 55, thermal class F, 400V-50Hz. With external frequency converter speed-adjustable in frequency range from 25 Hz up to 50 Hz - also in case of fire !



Technical data of the fan: REM BU-7180-63-24-50

fulfills the ErP requirements 2015

Description	Value Dimension
Specified duty point	
Actual duty point	
Installation acc. DIN 24163 Part 1	C
Reference density (Rho1)	1.20 kg/m ³
Medium temperature (t)	20 C
Fan weight	322 kg
Rated data	
Phases-Voltage-Frequency	3-400 D-50 V-Hz
Frame size-poles:	132M-6
Motor rating (P _N)	5.5 kW
Rated motor speed (n _N)	975 min ⁻¹
Rated motor current (I _N)	12,5 A
Max. temperature t _{max} , admitted for 120 min only	600 C
operational limits	
Max. fan speed (n _{vmax})	1000 min ⁻¹
Max. operating frequency (f _{max})	50 Hz
Temperature range of conveying medium (t _{min} ...t _{max})	-20...100 C
ErP-Data at best efficiency and density - kg/m³	
measurement- / efficiency category	B / total
design status of VSD	has to be installed
overall efficiency (ETA _{opt})	57.9 %
achieved efficiency grade (N _{ist})	61.7
required efficiency grade in 2013 / 2015 (N)	55 / 61
Air flow rate (V _{opt})	14732 m ³ /h
pressure rise (dp _{opt})	661 Pa
Fan speed (n _{vopt})	975 min ⁻¹
motor power input (P _{1opt})	4.67 kW
specific ratio (d _{dpopt})	1.007

Fan curve to REM BU-7180-63-24-50

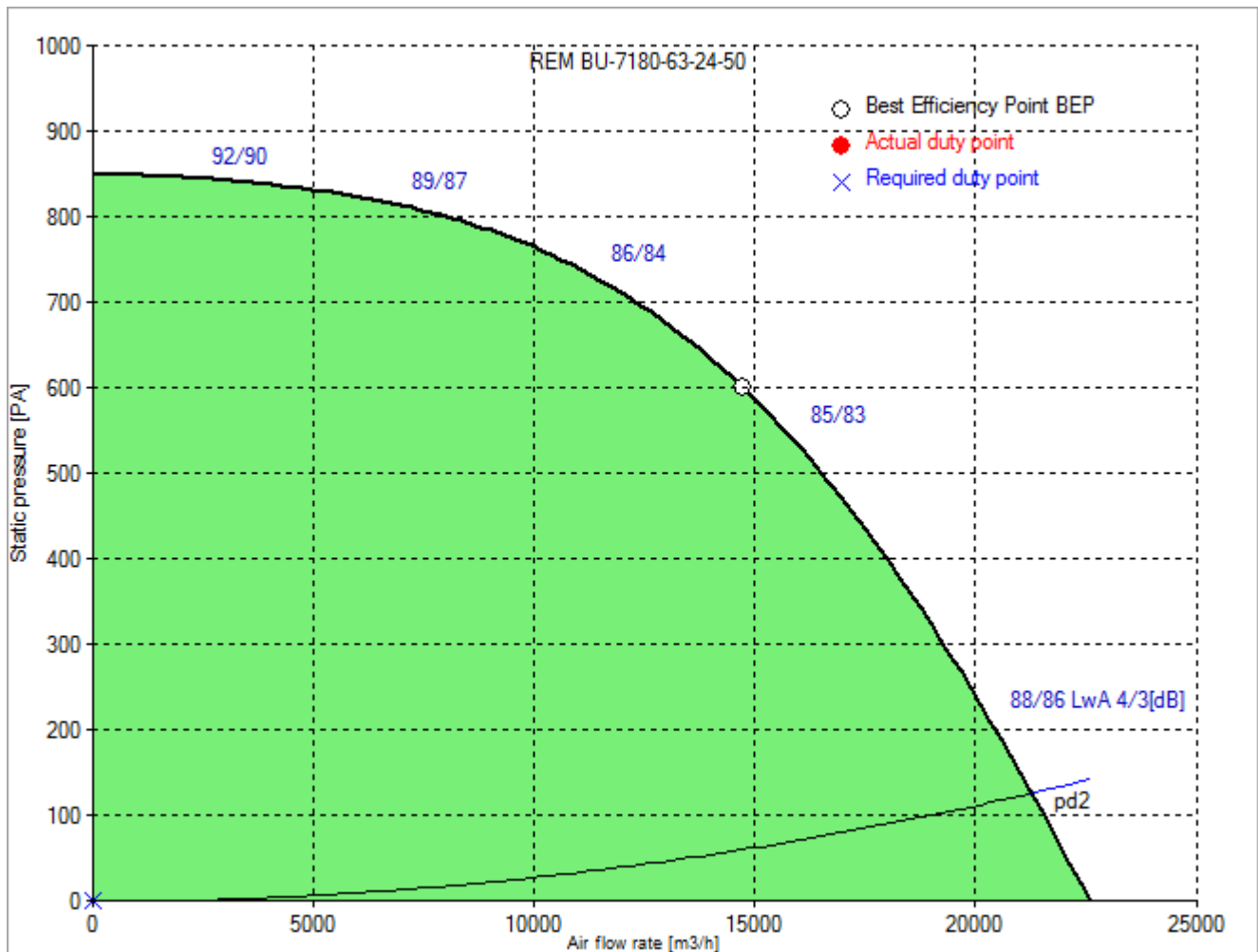

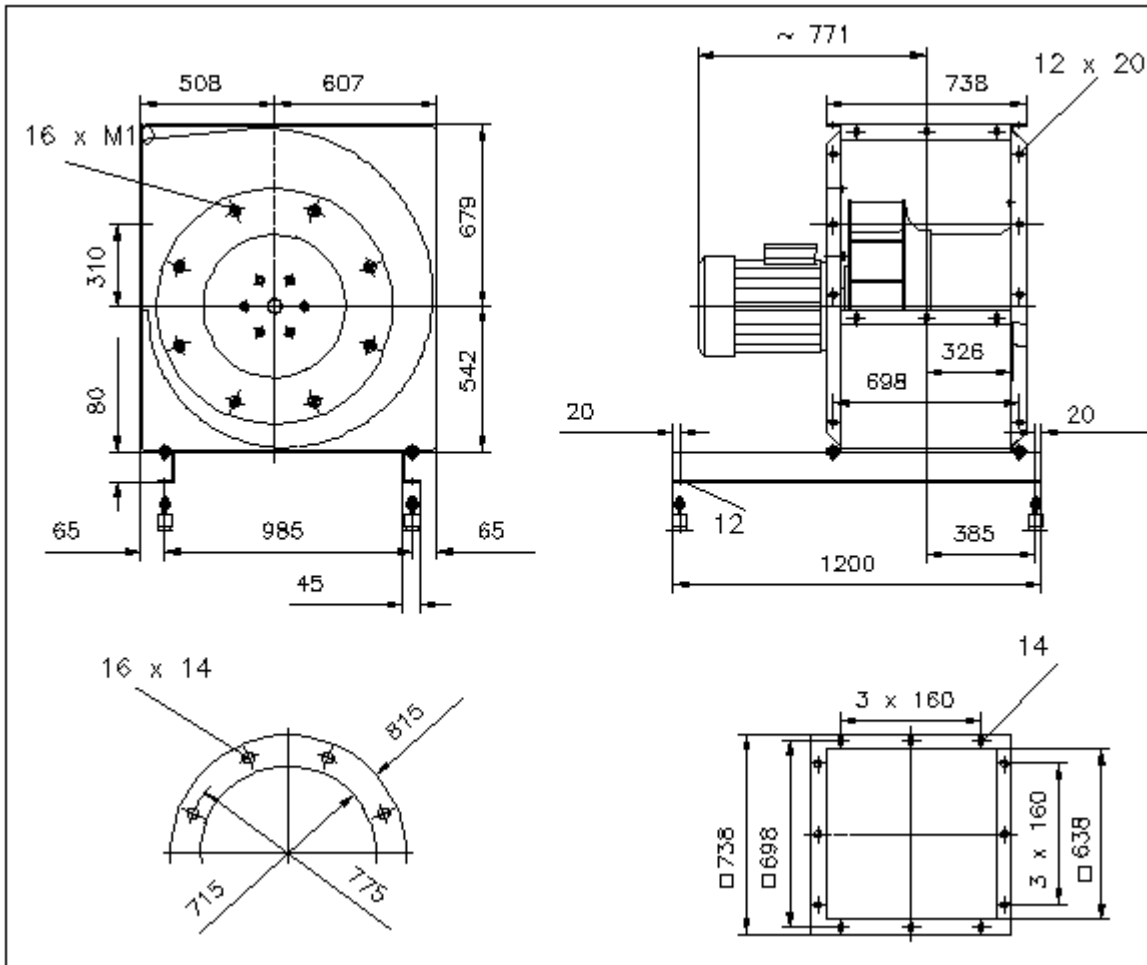

Rotation: RD
 Handing: 90

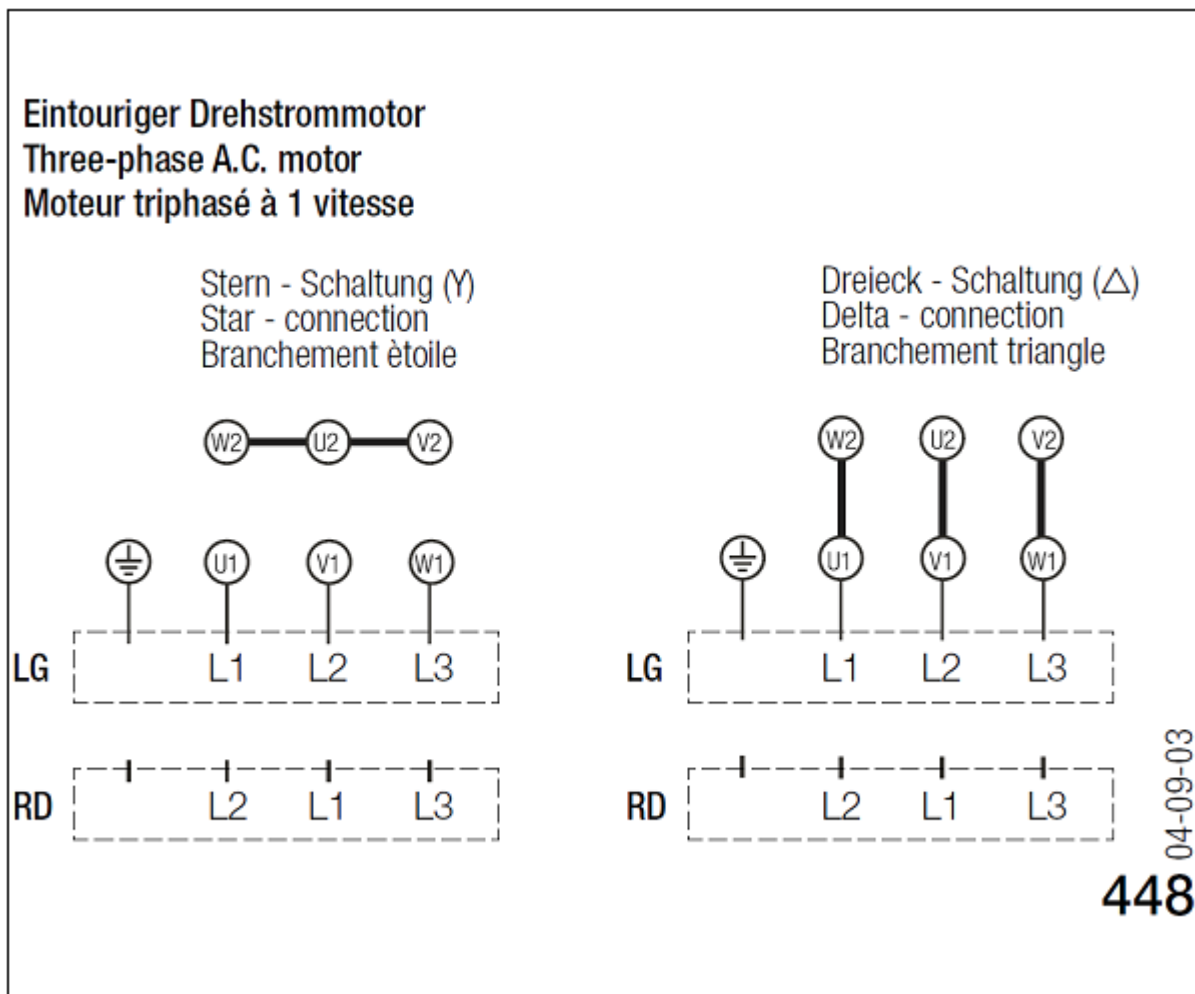

Wiring diagram for connection to: [mains - motor](#)
 Rotation: [RD](#)